



INTERNATIONAL APPLICATION PUBLISHED UNDER THE PATENT COOPERATION TREATY (PCT)

<p>(51) International Patent Classification ⁶ : H04B 15/00, 1/10, 7/10, H03D 1/00, 1/04</p>	<p>A1</p>	<p>(11) International Publication Number: WO 98/08319 (43) International Publication Date: 26 February 1998 (26.02.98)</p>
<p>(21) International Application Number: PCT/US97/14783 (22) International Filing Date: 22 August 1997 (22.08.97) (30) Priority Data: 60/024,525 23 August 1996 (23.08.96) US (71) Applicant: DATA FUSION CORPORATION [US/US]; Suite 1260, 9035 Wadsworth Parkway, Westminster, CO 80021 (US). (72) Inventors: KOBER, Wolfgang; 7017 South Richfield, Aurora, CO 80016 (US). THOMAS, John, K.; 569 West Street, Louisville, CO 80027 (US). (74) Agents: SWARTZ, Douglas, W. et al.; Sheridan Ross P.C., Suite 3500, 1700 Lincoln Street, Denver, CO 80203-4501 (US).</p>		<p>(81) Designated States: AL, AM, AT, AU, AZ, BA, BB, BG, BR, BY, CA, CH, CN, CU, CZ, DE, DK, EE, ES, FI, GB, GE, GH, HU, IL, IS, JP, KE, KG, KP, KR, KZ, LC, LK, LR, LS, LT, LU, LV, MD, MG, MK, MN, MW, MX, NO, NZ, PL, PT, RO, RU, SD, SE, SG, SI, SK, SL, TJ, TM, TR, TT, UA, UG, UZ, VN, YU, ZW, ARIPO patent (GH, KE, LS, MW, SD, SZ, UG, ZW), Eurasian patent (AM, AZ, BY, KG, KZ, MD, RU, TJ, TM), European patent (AT, BE, CH, DE, DK, ES, FI, FR, GB, GR, IE, IT, LU, MC, NL, PT, SE), OAPI patent (BF, BJ, CF, CG, CI, CM, GA, GN, ML, MR, NE, SN, TD, TG). Published <i>With international search report.</i></p>

(54) Title: RAKE RECEIVER FOR SPREAD SPECTRUM SIGNAL DEMODULATION

(57) Abstract

The architecture (54, 58, 60, 62, 66, 70, 74, 78, 82, 86, 90) of the present invention is premised upon an algorithm involving integration of oblique correlators (70) and RAKE filtering (62, 66, 82) to null interference from other spread spectrum signals. The oblique correlators (70) are, based on non-orthogonal projections that are optimum for nulling structured signals such as spread spectrum signals. RAKE filtering (62, 66, 82) is used to rapidly steer the beam of multi-antenna system to mitigate the effects of multipath.

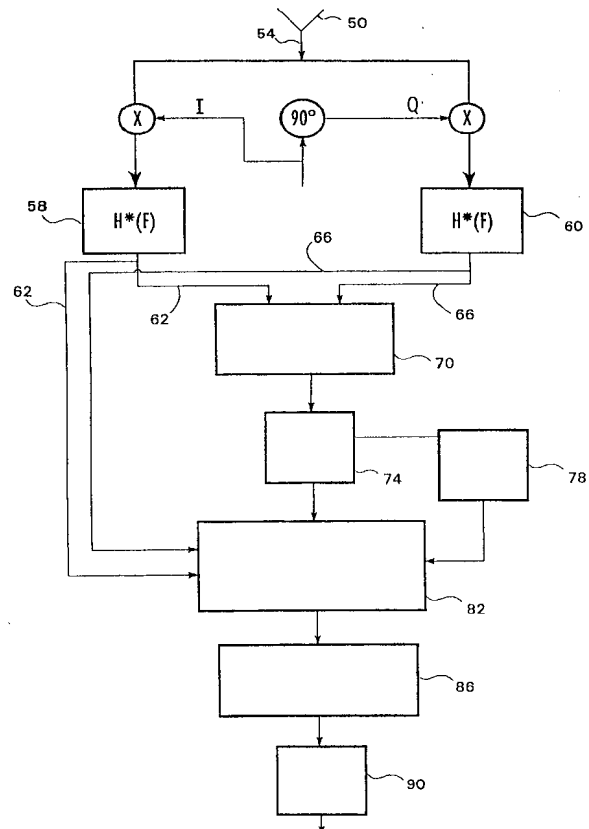

FOR THE PURPOSES OF INFORMATION ONLY

Codes used to identify States party to the PCT on the front pages of pamphlets publishing international applications under the PCT.

AL	Albania	ES	Spain	LS	Lesotho	SI	Slovenia
AM	Armenia	FI	Finland	LT	Lithuania	SK	Slovakia
AT	Austria	FR	France	LU	Luxembourg	SN	Senegal
AU	Australia	GA	Gabon	LV	Latvia	SZ	Swaziland
AZ	Azerbaijan	GB	United Kingdom	MC	Monaco	TD	Chad
BA	Bosnia and Herzegovina	GE	Georgia	MD	Republic of Moldova	TG	Togo
BB	Barbados	GH	Ghana	MG	Madagascar	TJ	Tajikistan
BE	Belgium	GN	Guinea	MK	The former Yugoslav Republic of Macedonia	TM	Turkmenistan
BF	Burkina Faso	GR	Greece	ML	Mali	TR	Turkey
BG	Bulgaria	HU	Hungary	MN	Mongolia	TT	Trinidad and Tobago
BJ	Benin	IE	Ireland	MR	Mauritania	UA	Ukraine
BR	Brazil	IL	Israel	MW	Malawi	UG	Uganda
BY	Belarus	IS	Iceland	MX	Mexico	US	United States of America
CA	Canada	IT	Italy	NE	Niger	UZ	Uzbekistan
CF	Central African Republic	JP	Japan	NL	Netherlands	VN	Viet Nam
CG	Congo	KE	Kenya	NO	Norway	YU	Yugoslavia
CH	Switzerland	KG	Kyrgyzstan	NZ	New Zealand	ZW	Zimbabwe
CI	Côte d'Ivoire	KP	Democratic People's Republic of Korea	PL	Poland		
CM	Cameroon	KR	Republic of Korea	PT	Portugal		
CN	China	KZ	Kazakistan	RO	Romania		
CU	Cuba	LC	Saint Lucia	RU	Russian Federation		
CZ	Czech Republic	LI	Liechtenstein	SD	Sudan		
DE	Germany	LK	Sri Lanka	SE	Sweden		
DK	Denmark	LR	Liberia	SG	Singapore		
EE	Estonia						

RAKE RECEIVER FOR SPREAD SPECTRUM SIGNAL DEMODULATION

FIELD OF THE INVENTION

The present invention is generally directed to a
5 system for receiving a spread spectrum signal and
specifically to a system for receiving and demodulating a
spread spectrum signal.

BACKGROUND OF THE INVENTION

10 Spread spectrum techniques are finding larger roles in
a variety of applications. In cellular telephony, spread
spectrum based systems offer the potential for increased
efficiency in the use of bandwidth. The resistance of
spread spectrum methods to jamming make them ideally suited
15 for radar and Global Positioning System (GPS) applications.
For radar applications, spread spectrum signals have a
lower probability of being intercepted due to the noise-
like appearance of spread spectrum waveforms. In addition,
it may be used to increase the pulse repetition frequency
20 without sacrificing unambiguous range.

In spread spectrum radars, GPS, and cellular telephony
applications (e.g., Code Division Multiple Access (CDMA)),
each transmitted signal or pulse is assigned a time varying
pseudo-random code that is used to spread each bit in the
25 digital data stream (i.e., an interference code), such as
the long code and PN code in CDMA applications. In CDMA
applications, this spreading causes the signal to occupy
the entire spectral band allocated to the Multiple Access
System (MAS). The different users in such a system are
30 distinguished by unique interference codes assigned to
each. Accordingly, all users simultaneously use all of the
bandwidth all of the time and thus there is efficient
utilization of bandwidth resources. In addition, since
signals are wide-band, the multipath delays can be
35 estimated and compensated for. Finally, by carefully
constructing interference codes, base-stations can operate
with limited interference from adjacent base stations and
therefore operate with higher reuse factors (i.e., more of
the available channels can be used).

-2-

In spread spectrum systems, all other spread spectrum signals contribute to background noise, or interference, relative to a selected spread spectrum signal. Because each user (or radar pulse or GPS satellite signal) uses a noise-like interference code to spread the bits in a signal, all the users contribute to the background noise. In CDMA systems in particular, user generated background noise, while having a minimal effect on the forward link (base-to-mobile) (due to the synchronized use of orthogonal Walsh Codes), has a significant effect on the reverse link (mobile to base) (where the Walsh Codes are commonly not synchronized and therefore nonorthogonal). The number of users a base-station can support is directly related to the gain of the antenna and inversely related to the interference. Gain is realized through the amplification of the signal from users that are in the main beam of the antenna, thereby increasing the detection probability in the demodulator. Interference decreases the probability of detection for a signal from a given user. Although "code" filters are used to isolate selected users, filter leakage results in the leakage of signals of other users into the signal of the selected user, thereby producing interference. This leakage problem is particularly significant when the selected user is far away (and thus the user's signal is weak) and the interfering user is nearby (and thus the interfering user's signal is strong). This problem is known as the near-far problem.

There are numerous techniques for improving the signal-to-noise ratio of spectrum signals where the noise in the signal is primarily a result of interference caused by other spread spectrum signals. These techniques primarily attempt to reduce or eliminate the interference by different mechanisms.

In one technique, the interfering signals are reduced by switching frequency intervals assigned to users. This technique is useless for the intentional jamming scenario in which jammers track the transmitter frequencies.

-3-

Frequency switching is not an option for the CDMA standard for cellular telephones. In that technology, all users use all of the frequencies at all times. As a result there are no vacant frequency bands to switch to. In another
5 technique, the interfering signals are selectively nulled by beam steering. Classical beamsteering, however, does not provide, without additional improvements, the required angular resolution for densely populated communications environments.

10 The above techniques are further hampered due to the fact that signals rarely travel a straight line from the transmitter to the receiver. In fact, signals typically bounce off of buildings, trees, cars, etc., and arrive at the receiver from multiple directions. This situation is
15 referred to as the multipath effect from the multiple paths that the various reflections that a signal takes to arrive at the receiver.

SUMMARY OF THE INVENTION

20 An objective of the present invention is to provide a system architecture for increasing the signal-to-noise ratio (SNR) of a spread spectrum signal. Another objective is to provide a system architecture for removing the interference from a spread spectrum signal, particularly
25 the interference attributable to spread spectrum signals generated by other sources. Yet another objective is to provide a system architecture for removing the interference from a spread spectrum signal that does not employ beam steering. Specific related objectives include providing a
30 demodulating/decoding system for efficiently demodulating/decoding spread spectrum signals generated by far away sources in the presence of spread spectrum signals generated by near sources and/or effectively accounting for the various multipaths of a spread spectrum signal.

35 These and other objectives are addressed by the spread spectrum system architecture of the present invention. The system includes: (i) an antenna adapted to receive a

-4-

signal, a first signal segment of the signal being attributable to a first source and a second signal segment of the signal being attributable to a source other than the first source; and (ii) an oblique projecting device, in communication with the antenna, for determining the first signal segment. The signal can be any structured signal, such as a spread spectrum signal. A "structured signal" is a signal that has known values or is created as a combination of signals of known values.

The oblique projecting device determines the first signal segment by obliquely projecting a signal space spanned by the signal onto a first space spanned by the first signal segment. As used herein, the "space" spanned by a set "A" of signals is the set of all signals that can be created by linear combinations of the signals in the set "A". For example, in spread spectrum applications, the space spanned by the signals in set "A" are defined by the interference codes of the one or more selected signals in the set. Thus the space spanned by interfering signals is defined by all linear combinations of the interfering signals. The signal space can be obliquely projected onto the axis along a second space spanned by the second signal segment. The estimated parameters of the first signal segment are related to the actual parameters of the first signal segment and are substantially free of contributions by the second signal segment. Through the use of oblique projection, there is little, if any, leakage of the second signal segment into computed parameters representative of the first signal segment.

For spread spectrum applications, oblique projection is preferably performed utilizing the following algorithm:

$$(y^T H (H^T (I - S (S^T S)^{-1} S^T) H)^{-1} H^T (I - S (S^T S)^{-1} S^T) y) / \sigma^2$$

where y corresponds to a selected portion of the spread spectrum signal, H corresponds to an interference code matrix for the first signal segment (which defines a first space including the first signal), S corresponds to the interference code matrices for signals of all of the other

-5-

sources (users) in the selected portion of the spread spectrum signal (which defines a second space including the signals of the other sources), T corresponds to the transpose operation and σ^2 corresponds to the variance of the magnitude of the noise in the selected portion of the spread spectrum signal.

The system can have a number of advantages, especially in spread spectrum systems. The system can significantly increase the signal-to-noise ratio (SNR) of the spread spectrum signal relative to conventional spread spectrum demodulating systems, thereby increasing the detection probability. This is realized by the almost complete removal (i.e., nulling) from the spread spectrum signal of interference attributable to spread spectrum signals generated by other sources. Non-orthogonal (oblique) projections are optimum for nulling structured signals such as spread spectrum signals. In CDMA systems, the system can efficiently demodulate/decode spread spectrum signals generated by far away (weak) sources in the presence of spread spectrum signals generated by near (strong) sources, thereby permitting the base station for a given level of signal quality to service more users and operate more efficiently. An improvement in SNR further translates into an increase in the user capacity of a spectral bandwidth -- which is a scarce resource. Unlike conventional systems, the system does not require beam steering to remove the interference.

In applications where the first signal includes a number of multipath signal segments, the system can include a threshold detecting device, in communication with the oblique projecting device, for generating timing information defining a temporal relationship among the plurality of multipath signal segments (e.g., using mathematical peak location techniques that find the points at which the slope of the surface changes from positive to negative and has a large magnitude) and a timing reconciliation device for determining a reference time

-6-

based on the timing information (i.e., the multipath delays). Multipath signal segments correspond to the various multipaths followed by a signal (e.g., the first signal) after transmission by the signal source.

5 The system can include a RAKE processor in communication with the oblique projecting device and the timing reconciliation device for aligning the plurality of multipath signal segments in at least one of time and phase and/or scaling the magnitude(s) of the multipath signal
10 segments. RAKE processing rapidly steers the beam of a multi-antenna system as well as mitigates multipath effects. The RAKE processor preferably aligns and scales using the following algorithm:

$$Y_R(K) = \frac{1}{P} \sum_{i=1}^P A_i e^{-j\phi_i} y(k+t_i)$$

where p is the number of the multipath signal segments (or
15 peaks); i is the number of the multipath signal segment; A_i is the amplitude of ith multipath signal segment; j is the amount of the phase shift; ϕ_i is the phase of the ith multipath signal segment; $y(k)$ is the input sequence; and t_i is the delay in the received time for the ith multipath
20 signal segment.

The RAKE processor effectively focuses the beam on the desired signal source. The oblique projecting device and RAKE processor null out the signals of other sources in the spread spectrum signal and thereby eliminate the need for
25 null steering to be performed by the antenna. The system of the present invention is less complex and more efficient than conventional beam steering systems.

The system can include a demodulating device in communication with the RAKE processor to demodulate each of
30 the signal segments. Like the oblique projecting device, the demodulating device uses the equation noted above with respect to the oblique projecting device. Unlike the

-7-

oblique projecting device which uses portions of the filtered signal to perform oblique projection, the demodulating device uses the output of the RAKE processor which has aligned and summed all of the multipath signal segments. Both the oblique projecting and demodulating devices use estimates of the transmission time ("transmission time") and symbol ("candidate symbol") and the receive time in determining a correlation function using the above equation. "Receive time" is the index into the received data stream (or spread spectrum signal) and represents the time at which the data (or spread spectrum signal) was received by the antenna. "Transmission time" is the time at which the source transmitted a selected portion of the data stream (i.e., the selected signal).

In another configuration, the system includes a plurality of antennas (i.e., an antenna array), with each antenna having a respective oblique projecting device, threshold detecting device, and RAKE processor. A common timing reconciliation device is in communication with each of the respective threshold detecting devices and RAKE processors. A common demodulating component is also in communication with each of the RAKE processors. In this configuration, the demodulating component sums all of the first signals received by each of the antennas to yield a corrected first signal reflecting all of the various multipath signal segments related to the first signal.

In either configuration, the system can effectively accommodate the various multipath signal segments related to a source signal. The RAKE processor weights each of the multipath signal segments in direct relation to the magnitude of the peak defined by each multipath signal segment.

BRIEF DESCRIPTION OF THE DRAWINGS

Fig. 1 is a first embodiment of the present invention;
Fig. 2 depicts the various components of the correlating device;

-8-

Fig. 3 depicts the unit steps performed by the components of Fig. 2;

Fig. 4 depicts graphically the oblique projecting operation;

5 Fig. 5 depicts the signal segments contained in a portion of the filtered signal;

Fig. 6 depicts the three dimensional correlation surface employed by the threshold detecting device;

10 Fig. 7 pictorially depicts the operation of the RAKE processor;

Fig. 8 depicts the various components of the demodulating device;

Fig. 9 depicts a correlation surface defined by the correlation function output by the demodulating device;

15 Fig. 10 is a second embodiment of the present invention for an antenna array;

Fig. 11 is the first part of a flow schematic of the software for operating the system of Fig. 10; and

Fig. 12 is the second part of the flow schematic.

20

DETAILED DESCRIPTION

The present invention provides a software architecture and the underlying mathematical algorithms for demodulating/decoding communications signals containing
25 interference noise. This invention is generally applicable to CDMA systems (and other spread spectrum systems), Frequency Division Multiple Access systems (FDMA) and Time Division Multiple Access systems (TDMA) and particularly
30 for spread spectrum systems, such as CDMA. In spread spectrum systems, interference noise is typically due to a dense population of signals using the same intervals of the frequency spectrum, such as in high user density cellular phone applications, or such as in the intentional
35 interference of radar or communication signals by nearby jammers.

Single Antenna Systems

An overview of the current architecture for detecting signals from an *i*th user in a CDMA system is illustrated in Fig. 1. The architecture employs a single antenna for receiving CDMA signals. The system includes the antenna 50 adapted to receive the spread spectrum signal and generate an output signal 54, filters 58 and 60 for filtering the in-phase ("I") and quadrature ("Q") channels to form filtered channel signals 62 and 66, a correlating device 70 for providing a hypothetical correlation function characterizing a filtered signal segment, which may be multipath signal segment(s) of a source signal (hereinafter collectively referred to as a "signal segment"), transmitted by a selected user, a threshold timing device 74 for generating timing information defining the temporal relationship among a plurality of peaks defined by the hypothetical correlation function, a timing reconciliation device 78 for determining a reference time based on the timing information, a RAKE processor 82 for aligning multipath signal segments for each selected user in time and phase and outputting an aligned signal for the selected user, a demodulating device 86 for demodulating aligned signals transmitted by each selected user into correlation functions and, finally, a threshold detecting device 90 for converting the correlation functions into digital information. As will be appreciated, a system configured for radar or GPS applications will not include some of these components, such as the filters 58 and 60.

The antenna can be of any suitable configuration for receiving a structured signal and providing the output signal based thereon, such as an antenna having one or a number of antenna elements. As will be appreciated, the output signal is a mix of a plurality of signal segments transmitted by a number of mobile units (or users). The output signal is coherently shifted down from radio frequency and split into an in-phase (I) channel and a quadrature (Q) channel.

-10-

The I and Q channels of the output signal are filtered by the filters, $H^*(f)$, designated as 58 and 60, to form the filtered signals 62 and 66. Filtered signal 62 corresponds to the I channel of the output signal while filtered signal
5 66 corresponds to the Q channel. The filters 58 and 60 are counterparts to the filter $H(f)$ applied at the mobile unit to contain the transmitted signal within the specified bandwidth.

Referring to Figs. 1-3, the correlating device 70
10 includes a user code generator 94, a projection builder 98, and a bank of projection filters 102. For each of the filtered signals 62 and 66, the user code generator 94 selects 106 a user (i.e., the selected user) transmitting a selected signal segment in a selected portion of the
15 filtered signal to be decoded, selects 110, for the selected user and signal segment, a set of trial transmit times ("trial times") and candidate symbols and, for each trial time and candidate symbol in the set, generates 114 a candidate user code (or interface code) for the selected
20 user and signal segment. In selecting trial times, the base-station is assumed to have approximate synchronization with each of the mobile units. Using this approximate synchronization, the base station has a set of trial times at which each selected mobile unit may have transmitted the
25 selected signal segment included in the filtered signals 62 and 66. For each trial time, t_p , in the set of trial times for the selected user and signal segment, the user code generator 94 generates one or more candidate user codes indexed by trial time and candidate symbol. The set of
30 trial times used by the user code generator for determining the set of candidate user codes for a given signal segment is determined by known techniques. Typically, the user code generator will use a time interval centered on the receive time for the signal segment that has a width of
35 about 200 milliseconds or less and more typically of about 50 milliseconds or less. These steps are repeated for each

-11-

of the active users transmitting signal segment(s) of the filtered signal.

The projection builder 98 selects 118 a portion of the filtered signal to process, collects 122 appropriate
 5 candidate user codes for the users transmitting signal segments of the selected filtered signal portion from the output of the user code generator, and, using the receive time offsets, trial times, and candidate symbols, creates 126 a set of hypothetical projection operators.

10 The hypothetical projection operators are generated using the algorithm:

$$H(H^T(I-S(S^T S)^{-1}S^T)H)^{-1}H^T(I-S(S^T S)^{-1}S^T)$$

where H corresponds to an interference code matrix for the selected signal segment, S corresponds to the interference
 15 code matrices for all of the other signal segments in the selected filtered signal portion, and ^T corresponds to the transpose operation. The variables H and S depend upon the interference codes determined by the user code generator 94. Accordingly, H and S depend, respectively, upon the
 20 transmit time for the selected signal segment, and the transmit times of all of the other signal segments in the selected filtered signal portion. Because the data is indexed by the receive time, S is also a function of the receive time.

25 To apply the above-equation, the projection builder 98 estimates the transmit times and symbols of each of the signal segments in the selected filtered signal portion. As noted, the trial time is an estimate of the transmit time and the candidate symbol of the symbol.

30 Next, the bank of projection filters 102, with one filter corresponding to each trial time and candidate symbol (i.e., to each hypothetical projection operator), provide a set of filter outputs (i.e., hypothetical correlation functions) to be threshold detected by the
 35 threshold detecting device 74. Each of the bank of projection filters correlates 130 a plurality of multipath signal segments for a given trial time and candidate

-12-

symbol. The projection filters 102 extract an estimated signal segment attributable to a given user from each selected filtered signal portion while simultaneously nulling out the other signal segments from other users.

5 The equation used to generate the various hypothetical correlation functions is:

$$(y^T)(\text{projection operator for selected signal portion})(y)/F^2$$

where y corresponds to the selected filtered signal portion 62 or 66 and σ^2 corresponds to the variance of the magnitude
10 of the noise portion contained in the respective filtered signal portion. The equation is based on oblique or non-orthogonal projections of y onto space spanned by H to null interference (i.e., interference from signal segments transmitted by other users) and yield the signal segment
15 transmitted by the selected user. Because the receive times for the various signal segments of a selected user are unknown, a number of signal segments of the user, each at a different receive-time offset, must be correlated by the bank of projection filters.

20 The oblique projection of y space 134 spanned by y onto H space 138 spanned by H to yield an estimate of the signal segment 142 is illustrated in Fig. 4. Y space 134 spanned by Y is obliquely projected onto the H space 138 along S space 146 spanned by S . Oblique projections are
25 more effective than orthogonal projections in removing interference attributable to the other users where the Walsh codes are not synchronized and thus not orthogonal, such as in the reverse link of a CDMA system. In such cases, the correlation function is independent of the
30 amplitudes of the signal segments of other users and, therefore, power control of the transmitter is not a significant consideration.

By way of illustration, Fig. 5 illustrates a four (4)
35 user system in which the various users are transmitting symbols representing bits of data. The source signals are received by the antenna 50 as a number of multipath signal segments. A first multipath signal segment 150 is

-13-

transmitted by a first user, a second multipath signal segment 154 by a second user, a third multipath signal segment 158 by a third user, a fourth multipath signal segment 162 by the first user, and a fifth multipath signal segment 166 from a fourth user. The projection builder 98 selects a first receive time offset Δt_1 and thereby selects the first, second and third multipath signal segments 150, 154 and 158. The width of the receive time offset is determined by the control system for the base station using known techniques. For the first multipath signal segment 150, the projection builder 98 employs Δt_1 and a trial time and candidate symbol in the projection operator equation and generates a hypothetical projection operator for the first user indexed by the trial time and candidate symbol. For the second multipath signal segment 154, the projection builder employs Δt_1 and a trial time and candidate symbol in the projection operator equation and generates a hypothetical projection operator for second user indexed by the trial time and candidate symbol. This operation is also performed for the third multipath signal segment 158 with a hypothetical projection operator for the third user being likewise generated. For the second receive time offset, Δt_2 , the projection builder repeats the above steps for each of the fourth and fifth multipath signal segments 162 and 166 to generate additional projection operators for the first and fourth users. Although the first and fourth multipath signals are multipaths of a common source signal, the hypothetical projection operators for the first and fourth multipath signal segments are different due to differing degrees of interference. These steps are repeated for subsequent receive time offsets. The number of receive time offsets generated is determined by the base station control system using known techniques. The bank of projection filters 102 then apply each of the hypothetical projection operators to the filtered signal portion corresponding to the respective receive time offset to develop a plurality of hypothetical correlation functions

-14-

for the various users. Each of the hypothetical correlation functions defines a correlation surface 170 of the type depicted in Fig. 6, where the horizontal axes represent receive time and trial time and the vertical axis represents the output of the correlation function for a specific pair of receive times and trial times. One correlation function corresponds to a source signal transmitted by the selected user. Each peak 174a-d represents a multipath signal segment of the source signal.

10

The threshold detecting device 74 uses the hypothetical correlation functions for each user that are outputted by the bank of projection filters 102 to determine the temporal locations of the various multipath signal segments in the hypothetical correlation function. Due to multipath delays, each hypothetical correlation function can have multiple peaks as shown in Fig. 6. As set forth above, the various peaks in the correlation surface can be isolated using known mathematical techniques. Using techniques known in the art and the temporal location of the peaks (or timing information) output by the threshold detecting device 74, the timing reconciliation device 78 determines a reference time for the RAKE processor 82. The reference time is based upon the receive times of the various peaks located by the threshold detecting device 74. The reference time is used by the RAKE processor 82 as the time to which all of the signal segments for a given user are aligned.

The RAKE processor 82 based on the timing information, the peak amplitudes of the hypothetical correlation function(s) detected by the threshold detecting device, and the filtered signals 62 and , 66 scales and aligns (in time and phase) the various multipath signal segments transmitted by a given user and then sums the aligned signal segments for that user. The RAKE processor 82 can be a maximal SNR combiner.

35

-15-

The operation of the RAKE processor is illustrated in Fig. 7 (for an antenna array). As noted, the output of the bank of projection filters is the hypothetical correlation function, which in multipath environments typically has multiple peaks. Assuming that there are p multipaths or signal segments and therefore p peaks, the RAKE process determines the amplitudes, $\{A_i\}_{i=1}^p$, time delays, $\{t_i\}_{i=1}^p$, and phase delays $\{\phi_i\}_{i=1}^p$. If $y(k)$ is a sequence defining the filtered signal 62 or 66, then the ARAKED@ sequence is $y_R(K)$:

$$Y_R(K) = \frac{1}{\sum_{i=1}^p A_i} \sum_{i=1}^p A_i e^{-j\phi_i} y(k+t_i)$$

Referring again to Fig. 7, the RAKE processor 82 first sums 178 the outputs of the various antenna elements, shifts 182 the various sequences in the outputs by the amounts of the multipath delays between the corresponding multipath signal segments of a selected signal segment, so that all multipath signal segments are perfectly aligned. It then weights each shifted multipath signal segment by the amplitude of the correlation function corresponding to that segment and sums 186 the weighted components to produce the aligned signal $y_R(k)$.

The demodulating device 86 correlates the ARAKED@ sequence, $y_R(k)$ with the appropriate replicated segment of the coded signal in the filter bank 102 to produce the correct correlation function for detection by a second threshold detecting device 90. Referring to Fig. 8, the demodulating device 86, like the correlating device 70 includes a user code generator 200, a projection builder 204, and a bank of projection filters 208. The projection builder 204 and bank of projection filters 208 use the equations set forth above to provide projection operators and correlation functions. Unlike the correlating device 70 which provides for a series of hypothetical projection operators and correlation functions based on the trial

-16-

time, receive time, and candidate symbol for each multipath signal segment, the demodulating device 86 uses the "RAKED" sequence which has only a single aligned signal segment rather than a plurality of independent multipath signal segments. Accordingly, the demodulating device 86 is able to reliably estimate the actual transmit time for the source signal and therefore requires considerably less processing to determine a correlation function than the correlating device 70.

For each of the I and Q channels, the user code generator 200 in the demodulating device 86 selects the user to decode for each aligned signal segment, selects a transmit time and symbol for the aligned signal segment and, for each transmit time and symbol, generates the user or interference code for the selected user .

The projection builder 204 selects a portion of the "RAKED" sequence to process, collects the pertinent user codes from the user code generator 200, and, using the receive times, transmit times, and symbols, creates a series of projection operators for each aligned signal segment in the "RAKED" sequence.

Next, the bank of projection filters 208, with one filter corresponding to each pair of transmit times and symbols and therefore each projection operator, provides a set of filter outputs (e.g., correlation functions) each defining a second correlation surface to be threshold detected.

The second correlation surface is then detected by a second threshold detecting device 90 to determine the actual transmit time and symbol for each aligned signal. Fig. 9 depicts a representative correlation surface 212 corresponding to a correlation function determined by one projection filter. Compared to the correlation surface 170 of Fig. 6, the correlation surface 212 has only a single peak 214 (due to the alignment of the multipath signal segments in the "RAKED" sequence) as opposed to multiple peaks.

-17-

Using the transmit time and symbol, the aligned signal segment can be despread to provide the digital data for the aligned signal segment transmitted by each user.

Because the above-described system assumes that the interference from other users is substantially the same for all multipath signal segments and/or that the amount of the interference in each multipath signal segment is relatively small, the RAKE processor 82 and demodulating device 86 require reconfiguration in applications where the interference in each of the multipath signal segments is substantially different and the interference is significant. To accommodate the differing interference portions in each multipath signal segment, the user code generator 200, projection builder 204, and bank of projection filters 208 process each multipath signal segment, corresponding to a peak in the correlation surface, before the RAKE processor has aligned, scaled, and summed each of the multipath signal segments. After the interference portion of each multipath signal segment is removed by oblique projection techniques from that signal segment, the various multipath signal segments can be aligned, scaled, and summed by the RAKE processor as set forth above. Alignment and scaling can be performed after oblique projection is completed as to a given multipath signal segment or after all oblique projection is completed for all multipath signal segments.

Multiple Antenna Systems

Fig. 10 depicts a multiple antenna system according to another embodiment of the present invention. Each antenna 50a-n is connected to filters 250a-n and 254a-n, correlating device 258a-n, threshold detecting device 262a-n, and a RAKE processor 266a-n. The threshold detecting devices 262a-n for all of the antennas 50a-n are connected to a common timing reconciliation device 270, which in turn is connected to all of the RAKE processors 266a-n. In this manner, all of the RAKE processing for all of the filtered

-18-

signals is performed relative to a common reference time. The output of the RAKE processors 266a-n is provided to a common demodulating device 274 for determination of the correlation functions and summing of the signal portions received by all of the antennas that are attributable to a selected user. The system in effect phases the output of each antenna in order to maximize the SNR.

As will be appreciated, the output of each antenna in a conventional antenna array contains a desired signal but at a delay relative to the outputs of the other antennas. The amount of relative delay is a function of the arrangement of the antennas as well as the angular location of the source. Conventional beam-steering methods attempt to compensate for this time delay so that the desired signals add constructively thereby increasing the power of the desired signal. In general, an N antenna system can improve the SNR by a factor of N.

In the multiple antenna system of the present invention, by contrast, the compensation for the relative delays is performed in the RAKE processors 266a-n. In order to accomplish this, the system sums the antenna outputs without compensating for the relative delays. The correlation process may result in Np peaks as opposed to just p multipath induced peaks. These Np peaks are then used to align and scale the various signal segments prior to summation. The RAKE processor, in effect, performs the phase-delay compensation usually done in beam-steering.

The system architecture of the present invention thus does not require knowledge of array geometries and steering vectors. It does not require iterative searches for directions as is the case for systems that steer the beam using techniques like LMS and its variants. Finally, it is computationally very efficient.

Referring to Figs. 11-12, the software to operate the multiple antenna system of Fig. 10 will now be described. The software detects spread spectrum signals in the presence of interference from other users.

-19-

Initially, a channel is opened 278 to the respective antenna 50a-n, and a user is selected 282 to demodulate the signal segments transmitted by the selected user. The outputted spread spectrum signal of the respective antenna
5 50a-n is converted 286 into the I and Q channels. The channels are filtered by the filters 250a-n and 254a-n to form the filtered signals 290a-n and 294a-n. As will be appreciated, the filtering operation is generally not performed in radar and GPS applications.

10 Filtered signal portions are selected 298 for processing. In the query box 302, if other users are present in the selected filtered signal portion, PZ_s is set 306 based on candidate interference codes. If not, PZ_s is set 310 to I.

15 After the user is selected in box 282, trial times are generated 314 for the selected user. Next, candidate user codes are generated 318 for each of the trial times.

Next, hypothetical projection operators are created 322 for each trial time and filtered signal portion to be
20 processed. The filtered signal portion is correlated 326 by user with the trial time, receive time, and candidate symbol to create the hypothetical correlation function. The hypothetical correlation function characterizes the multipath signal segments from the user of interest while
25 nulling out the interference from other known users.

A correlation surface is generated and thresholded 330 to identify peaks in the hypothetical correlation functions.

30 Based on the receive times for all multipath signal segments for a given source signal received by each of the antennas, timing reconciliation 334 is performed. The minimum receive time of all of the corresponding multipath signal segments is selected as the reference time.

35 Based on the magnitudes of the peaks and the estimated receive times and the reference time, RAKE processing 338 is performed on all of the data segments.

-20-

The outputs from all of the RAKE processors 266a-n are combined 342 to formed a combined output.

Using the correct user codes and the correct interference codes, which are provided by RAKE processing, projection operators are created 346 for each data segment.

Based on the projection operators and the combined output, the aligned multipath signals segments for all of the antennas are correlated 350 and a second correlation surface generated.

Threshold detection 354 is performed to provide the digital data. The above-noted steps are repeated for other users and/or other multipath signal segments.

Location Using Multiple Antenna System

The multiple antenna system of Fig. 10 can be utilized to locate the source of a selected signal by triangulation. In case the multiple antennas on a base-station are evenly spaced, with spacing d , then the time difference between when the first signal from the source impinges on any two antennas can be used to estimate direction of arrival of the signal. This approach assumes that the first signal is a direct signal from the source. If θ is the angle to the source and t_0 is the time delay from when the first signal hits the first antenna and then the second antenna, then the formula for computing θ is

$$\theta = \sin^{-1} \left(\frac{ct_0}{d} \right)$$

where

d -antenna spacing

c -speed of light

Using ranging protocols currently in base-stations, one can obtain estimates of range to the source. This range information either alone or in combination with angle estimates, when obtained from multiple base-stations, can be processed using decentralized filtering algorithms to

-21-

get accurate location information about the source. The decentralized filtering algorithms are known. Examples of decentralized filtering algorithms include decentralized Kalman filters and the Federated filter.

5 While various embodiments of the present invention have been described in detail, it is apparent that modifications and adaptations of those embodiments will occur to those skilled in the art. However, it is to be expressly understood that such modifications and
10 adaptations are within the scope of the present invention, as set forth in the following claims.

-22-

What is claimed is:

1. A system for receiving a structured signal, comprising:

5 an antenna adapted to receive a signal, the signal having a first signal segment attributable to a first source and a second signal segment attributable to a source other than the first source; and,

10 oblique projecting means for determining the first signal segment of the signal, the first signal segment of the signal defining a first space, the oblique projecting means being in communication with the antenna and determining the first signal segment of the signal by obliquely projecting a signal space defined by the signal onto the first space.

15 2. The system of Claim 1 wherein the signal space is obliquely projected onto the first space along a second space corresponding to the second signal segment of the signal.

20 3. The system of Claim 1 wherein the system includes:

a) a plurality of antennas, each of which receives a portion of the signal, and

25 b) a plurality of oblique projecting means corresponding with a plurality of antennas and being in communication therewith, each of the plurality of oblique projecting means being adapted to determine by oblique projection the first signal segment of the respective signal portion received by the corresponding antenna.

30 4. The system of Claim 3 including a plurality of RAKE processors corresponding with the plurality of oblique projecting means, wherein each of the plurality of oblique projecting means produces a respective oblique projecting means output which is received as a RAKE processor input by its corresponding RAKE processor, the respective output of
35 each of the plurality of oblique projecting means being delayed relative to one another, each of the plurality of

-23-

RAKE processors being adapted to align and scale their respective inputs to produce a compensated output.

5 5. The system of Claim 4 wherein the compensated outputs of each of the plurality of RAKE processors is delivered to a summing correlator.

6. The system of Claim 1 including a RAKE processor having a RAKE input, wherein the oblique projecting means produces an oblique projecting means output which is coupled to the RAKE processor input.

10 7. The system of Claim 1, wherein the first signal segment comprises a plurality of multipath signal segments and the oblique projecting means outputs a correlation function having a plurality of peaks corresponding to the plurality of multipath signal segments, and further comprising:

15 threshold detecting means, in communication with the oblique projecting means, for generating timing information defining a temporal relationship among the plurality of peaks.

20 8. The system of Claim 7, wherein the system comprises a plurality of antennas in communication with a corresponding threshold detecting means and further comprising:

25 timing reconciliation means for determining a reference time based on timing information received from each of the threshold detecting means.

9. The system of Claim 8, further comprising:

30 a RAKE processing means, in communication with the oblique projecting means and the timing reconciliation means, for aligning the plurality of multipath signal segments in at least one of time and phase as a function of at least one of the magnitudes of the plurality of multipath signal segments, the reference time, and the phase, the phased RAKE means outputting an aligned first
35 signal.

-24-

10. The system of Claim 9, further comprising:

a plurality of RAKE processing means, each RAKE processing means being in communication with a corresponding one of the plurality of antennas and
5 producing a corresponding aligned first signal; and

a demodulating means, in communication with the plurality of RAKE processing means, for demodulating at least a portion of each corresponding aligned first signal, the at least a portion of each corresponding aligned first
10 signal defining a respective aligned first space, the demodulating means determining the respective corresponding aligned first signals by obliquely projecting a respective signal space defined by a corresponding aligned signal onto the respective aligned first space.

11. A system for receiving a spread spectrum signal,
15 comprising:

an antenna adapted to receive a spread spectrum signal and adapted to generate an output signal, the output signal comprising:

20 (i) a first signal attributable to a first source,
(ii) a second signal portion attributable to a second source other than the first source,
(iii) a noise portion, the noise portion having a magnitude; and,

25 oblique projecting means for determining the first signal of the output signal, the oblique projecting means being in communication with the antenna and determining the first signal of the output signal by the following equation:

$$30 \quad (y^T H (H^T (I - S (S^T S)^{-1} S^T) H)^{-1} H^T (I - S (S^T S)^{-1} S^T) y) / \sigma^2$$

wherein y corresponds to the output signal, H is related to an interference code matrix of the first source, S is related to an interference code matrix of the second source, T denotes the transpose operation, I denotes the
35 identity matrix, and σ^2 corresponds to the variance of the magnitude of the noise portion.

12. The system of Claim 11 wherein the antenna includes a receiver and at least a portion of the noise is generated by the receiver.

13. The system of Claim 11 including a plurality of
 5 oblique projecting means corresponding to a plurality of antennas and being in communication therewith, each of the plurality of oblique projecting means being adapted to determine a respective first signal of a corresponding
 10 portion of the spread spectrum signal received by each of the plurality of antennas and determine the respective first signal of the spread spectrum signal by the equation:

$$(y^T H (H^T (I - S (S^T S)^{-1} S^T) H)^{-1} H^T (I - S (S^T S)^{-1} S^T) y) / \sigma^2.$$

14. The system of Claim 13 including a plurality of
 15 RAKE processors corresponding with the plurality of oblique projecting means, wherein each of the plurality of oblique projecting means produces an oblique projecting means output which is received as a RAKE processor input by its
 20 corresponding RAKE processor, the output of each of the plurality of oblique projecting means being delayed relative to one another, each of the plurality of RAKE processors being adapted to align and scale their
 25 respective inputs to produce a compensated output.

15. The system of Claim 14 wherein the compensated
 25 outputs of each of the plurality of RAKE processors are delivered to a second oblique projecting means for determining a refined first signal of each of the compensated outputs by the equation $(y^T H (H^T (I - S (S^T S)^{-1} S^T) H)^{-1} H^T (I - S (S^T S)^{-1} S^T) y) / \sigma^2.$

16. The system of Claim 11, wherein the first signal
 30 comprises a plurality of multipath signal segments and the oblique projecting means outputs a correlation function having a plurality of peaks corresponding to the plurality of multipath signal segments, and further comprising:

35 threshold detecting means, in communication with the oblique projecting means, for generating timing information defining a temporal relationship among the plurality of peaks.

-26-

17. The system of Claim 16, wherein the system comprises a plurality of antennas in communication with a corresponding threshold detecting means and further comprising:

5 timing reconciliation means for determining a reference time based on timing information received from each of the threshold detecting means.

18. The system of Claim 17, further comprising:

10 a RAKE processing means, in communication with the oblique projecting means and the timing reconciliation means, for aligning the plurality of multipath signal segments in at least one of time of phase based on the magnitudes of the plurality of multipath signal segments and the reference time to form an aligned first signal.

15 19. A method for demodulating a structured signal, the structured signal comprising a first signal attributable to a first source and a second signal attributable to a second source other than the first source, the first signal corresponding to a first vector, the method comprising the steps of:

(a) receiving the structured signal; and,

(b) obliquely projecting a signal space corresponding to the signal onto a first space defined by the first signal.

25 20. The method of Claim 19 wherein, in the obliquely projecting step, the signal space is obliquely projected onto the first space a second space corresponding to the second signal.

30 21. The method of Claim 19 wherein the obliquely projecting step determines the magnitude of the first signal.

22. The method of Claim 19, wherein the first signal comprises a plurality of multipath signal segments and further comprising:

35 aligning at least one of a received time and phase of the multipath signal segments to produce an aligned first signal.

-27-

23. The method of Claim 22, further comprising:
scaling the multipath signal segments.

24. The method of Claim 19, wherein the first signal
comprises a plurality of multipath signal segments, each of
5 the plurality of multipath signal segments being received
at different times, and further comprising:

assigning to a portion of each of the plurality of
multipath signal segments a respective time of receipt.

25. The method of Claim 24, further comprising:
10 determining a reference time of receipt based on the
respective times of receipt.

26. The method of Claim 25, further comprising:
first summing the plurality of multipath signal
segments without regard to the differing times of receipt
15 to form a summated peak magnitude;

second aligning the plurality of multipath signal
segments relative to the reference time of receipt to form
a plurality of aligned signals;

20 scaling each of the multipath signal segments to form
a plurality of scaled signals; and

third summing at least one of the aligned signals and
the scaled signals.

27. The method of Claim 21, further comprising:
25 determining an actual time of transmission of the
first signal;

determining an actual received time for the first
signal; and

repeating step (b) using the actual time of
transmission and the actual received time.

30

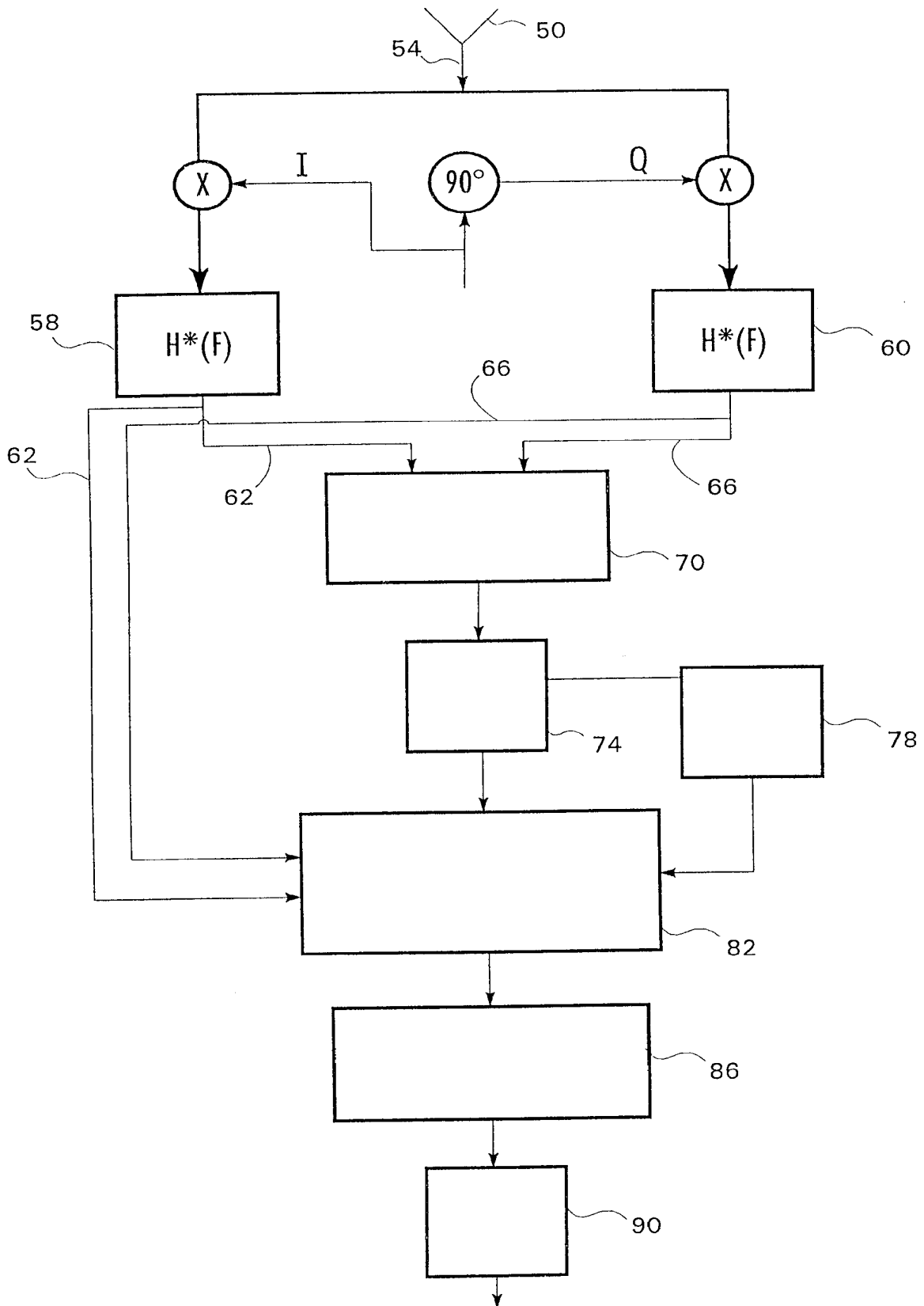

FIG. 1

OBLIQUE CORRELATION

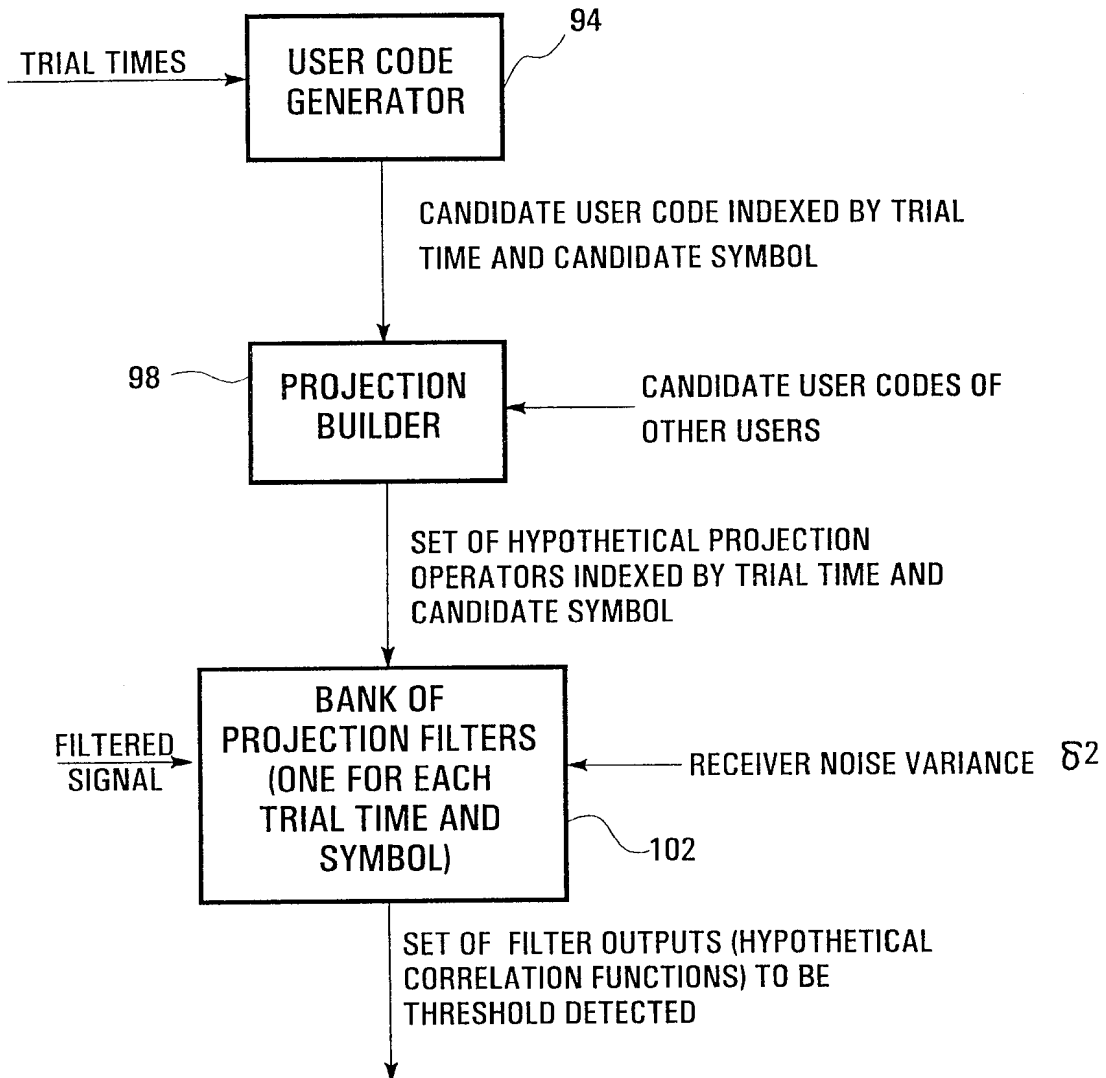

FIG. 2

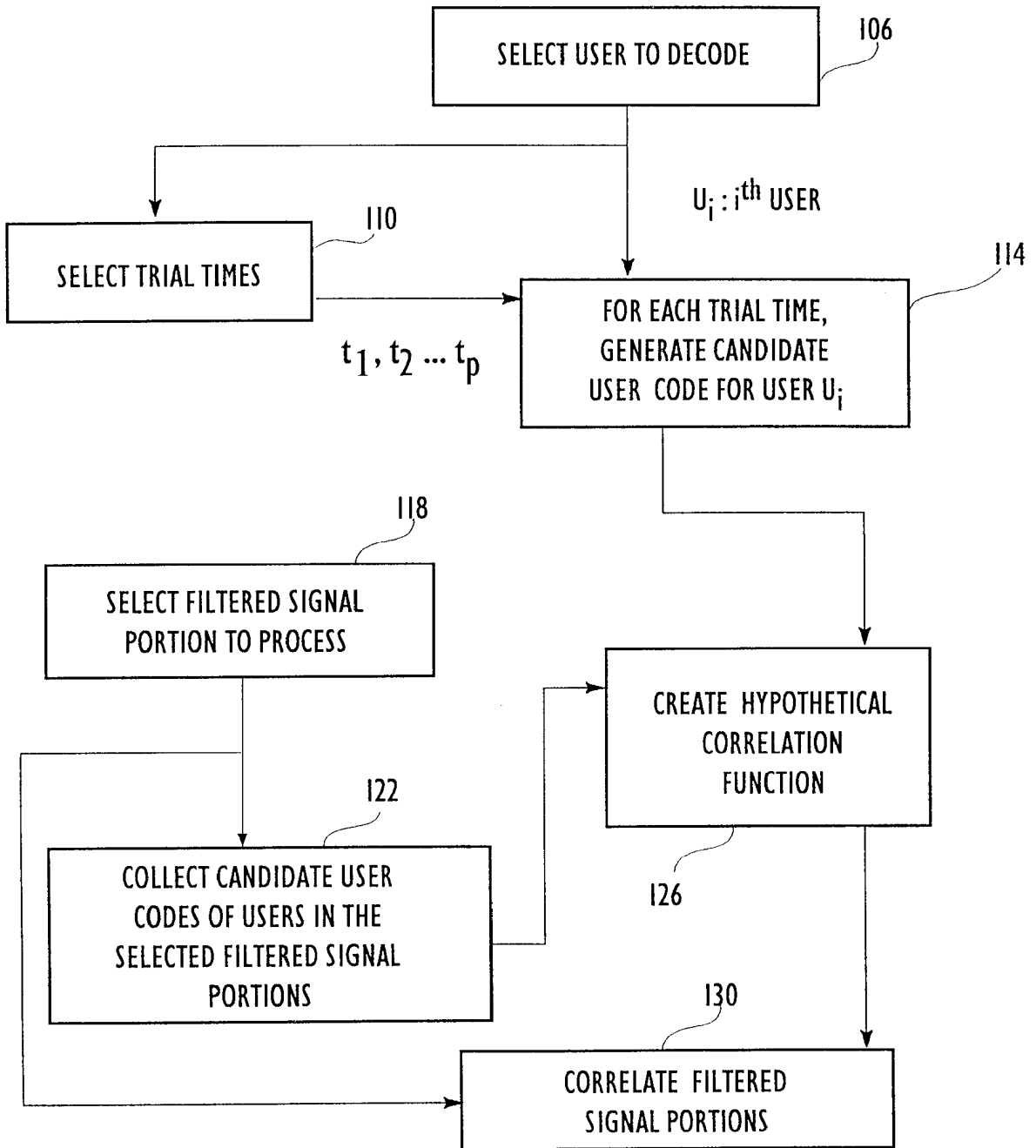
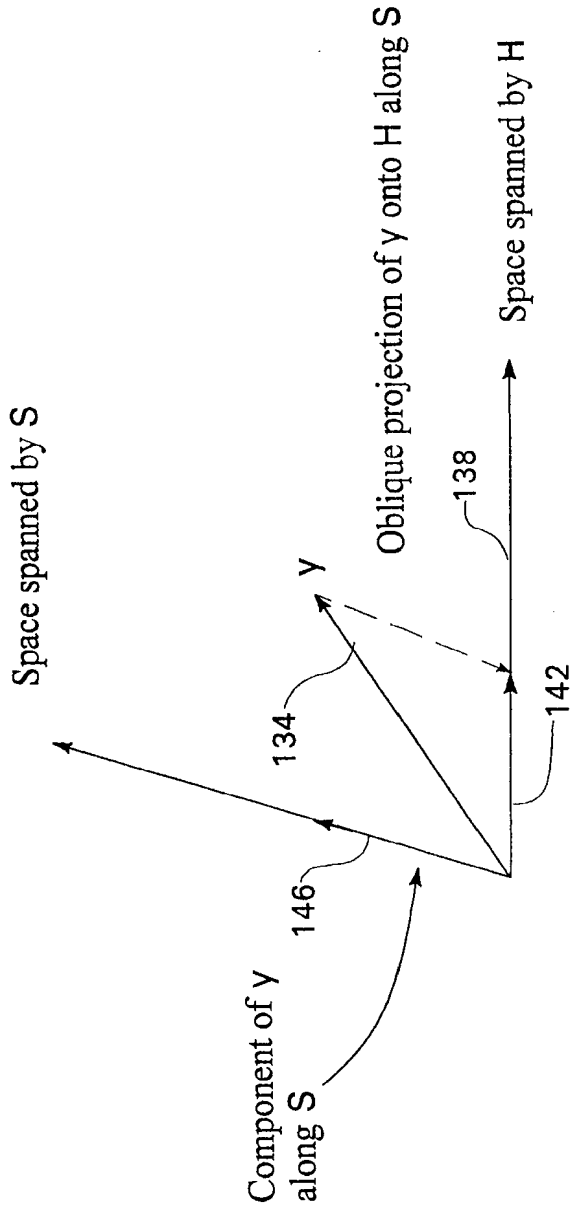

FIG. 3



NO LEAKAGE FROM THE COMPONENTS OF S

**FIGURE 4 -
Geometrical Interpretation
of Oblique Filtering**

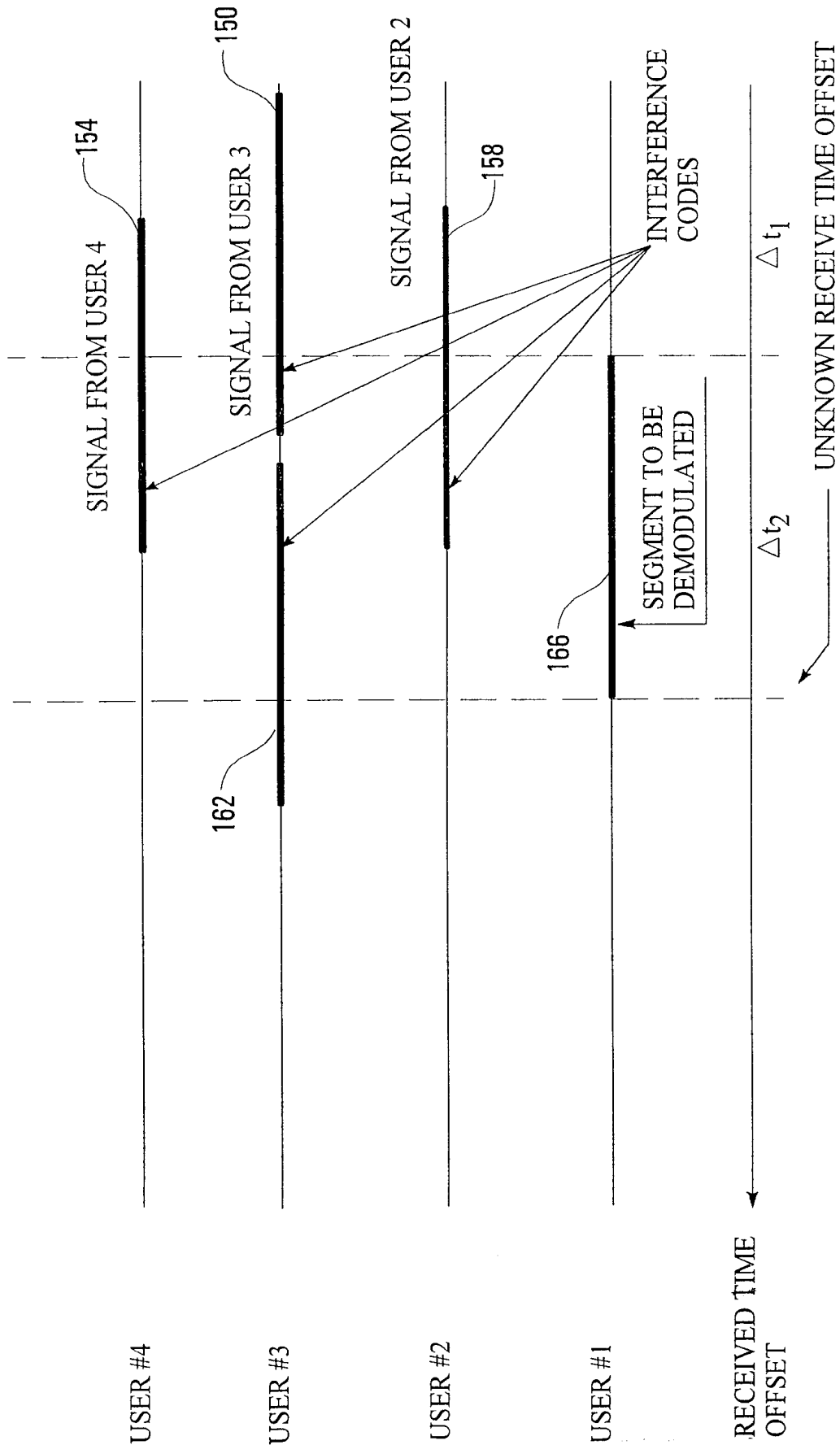

FIGURE 5

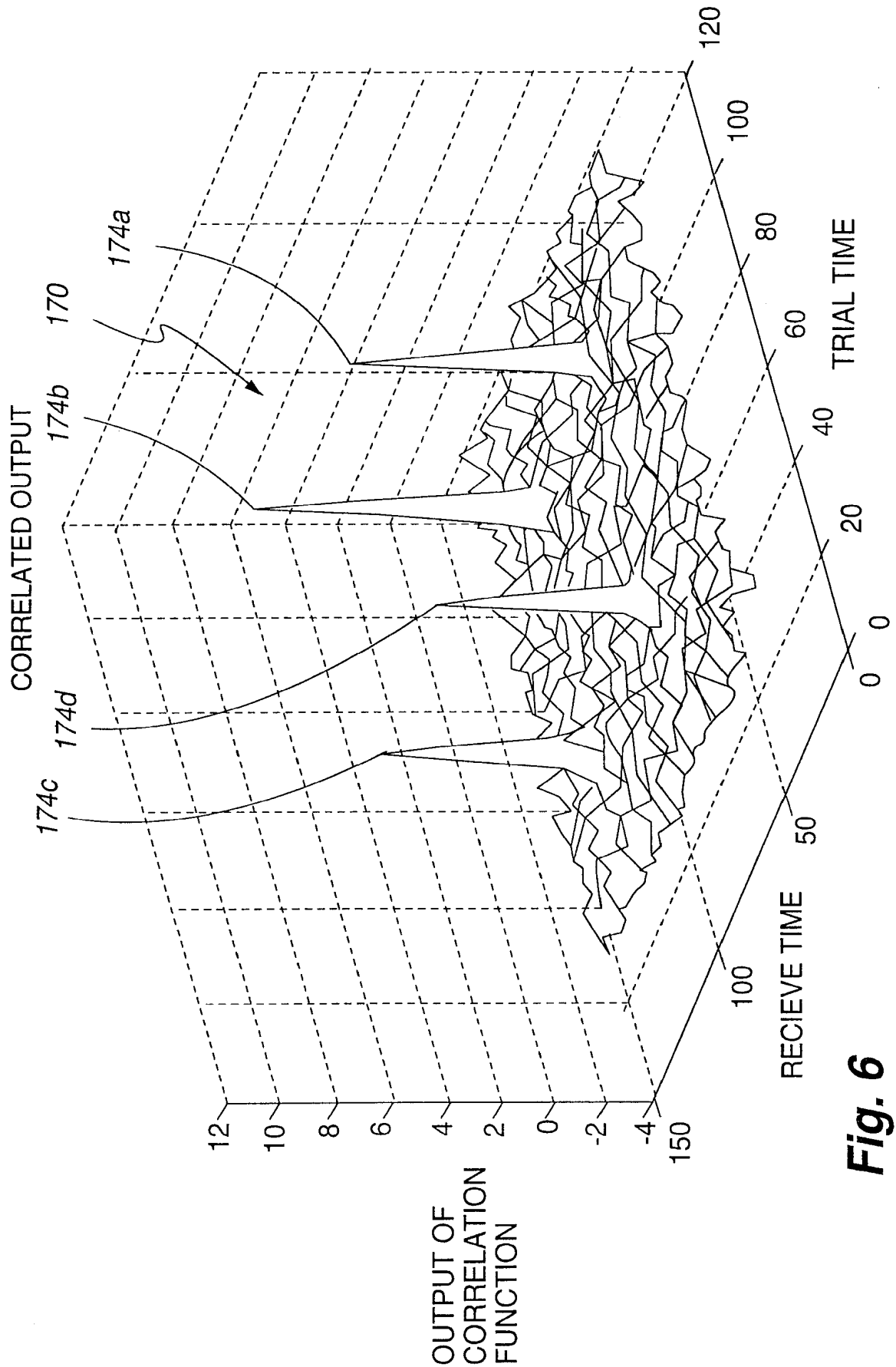
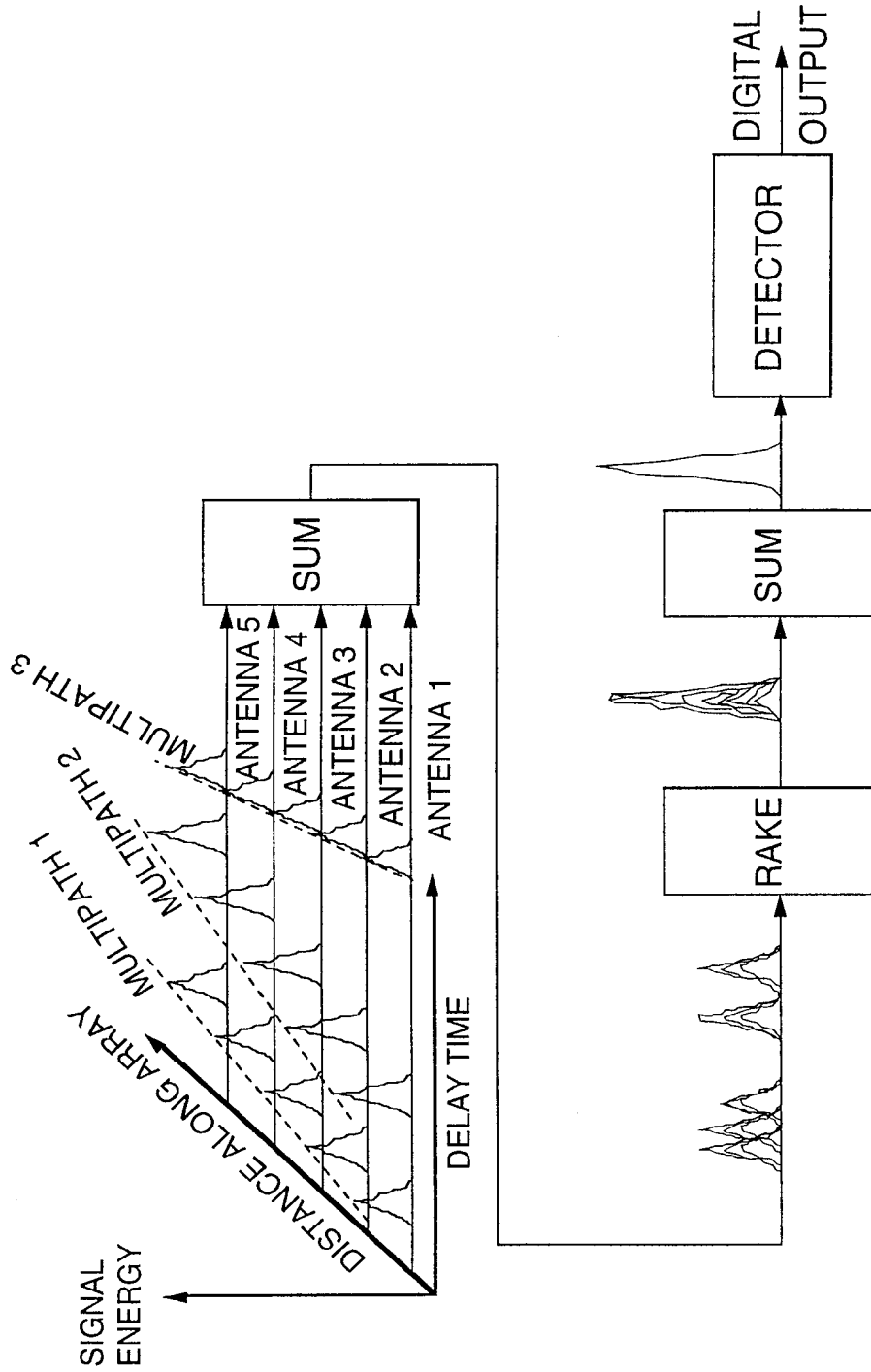

Fig. 6

+

7/12



PHASED RAKE PROCESSING

FIG. 7

+

OBLIQUE CORRELATION

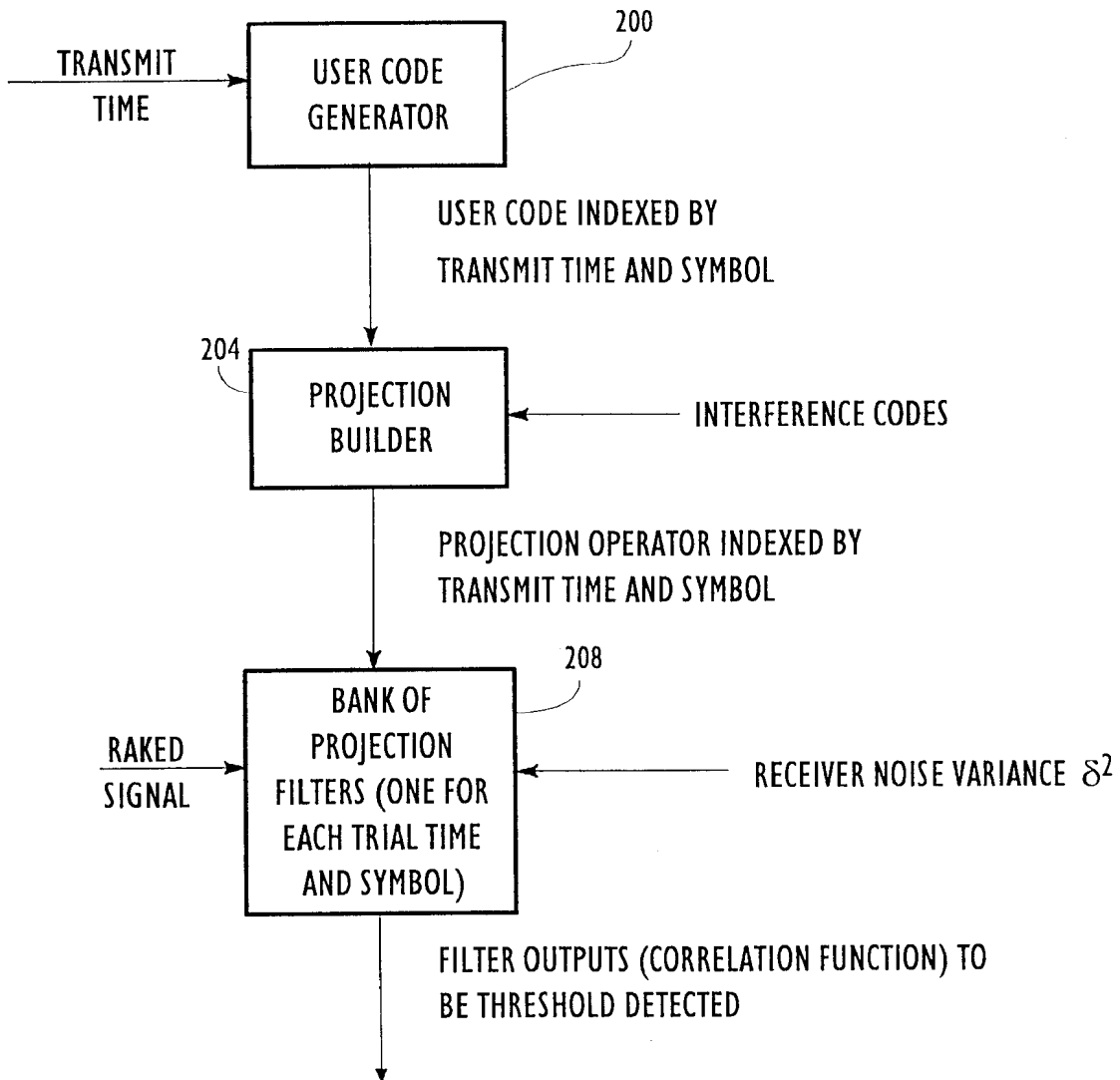

FIG. 8

+

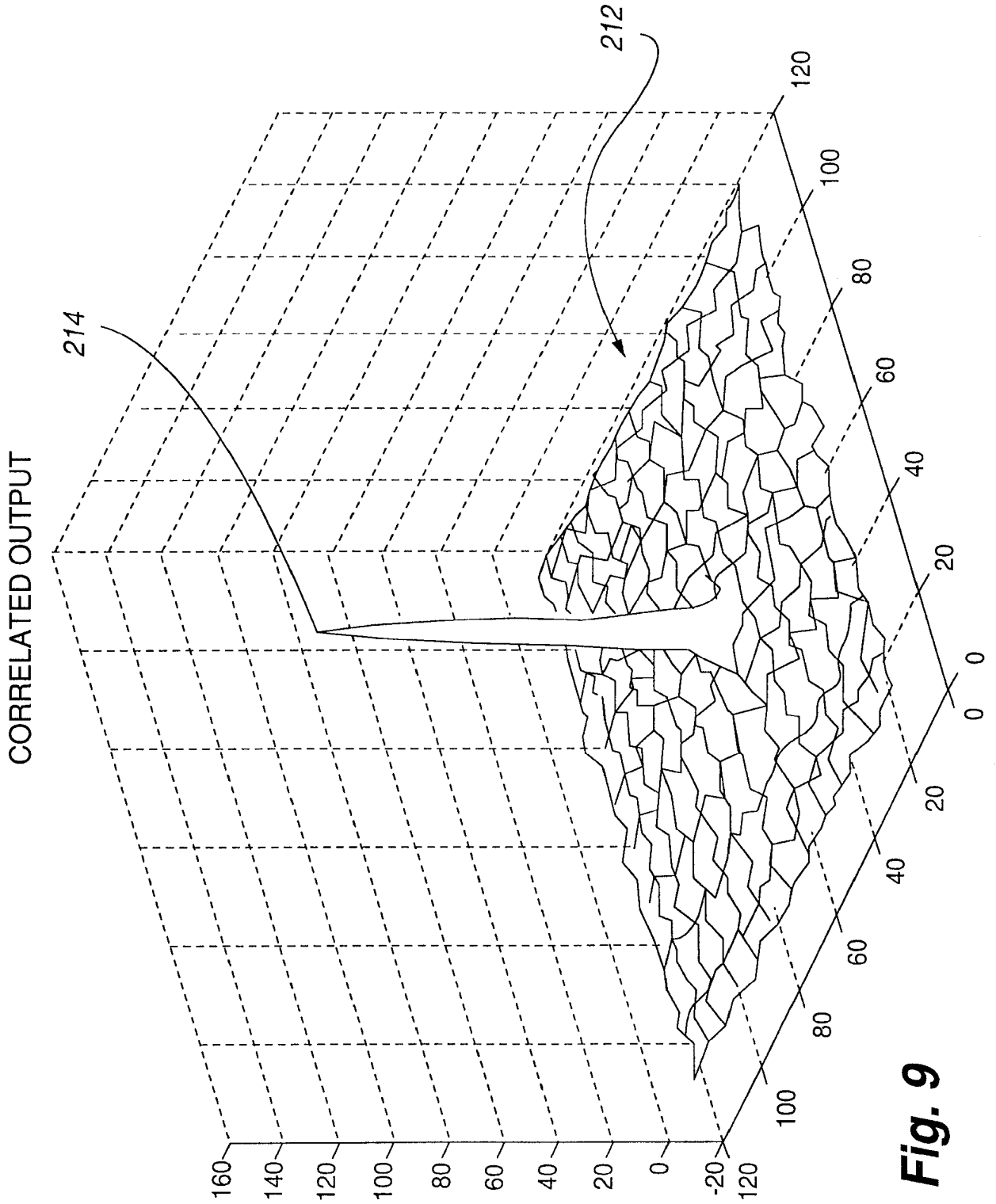

Fig. 9

+

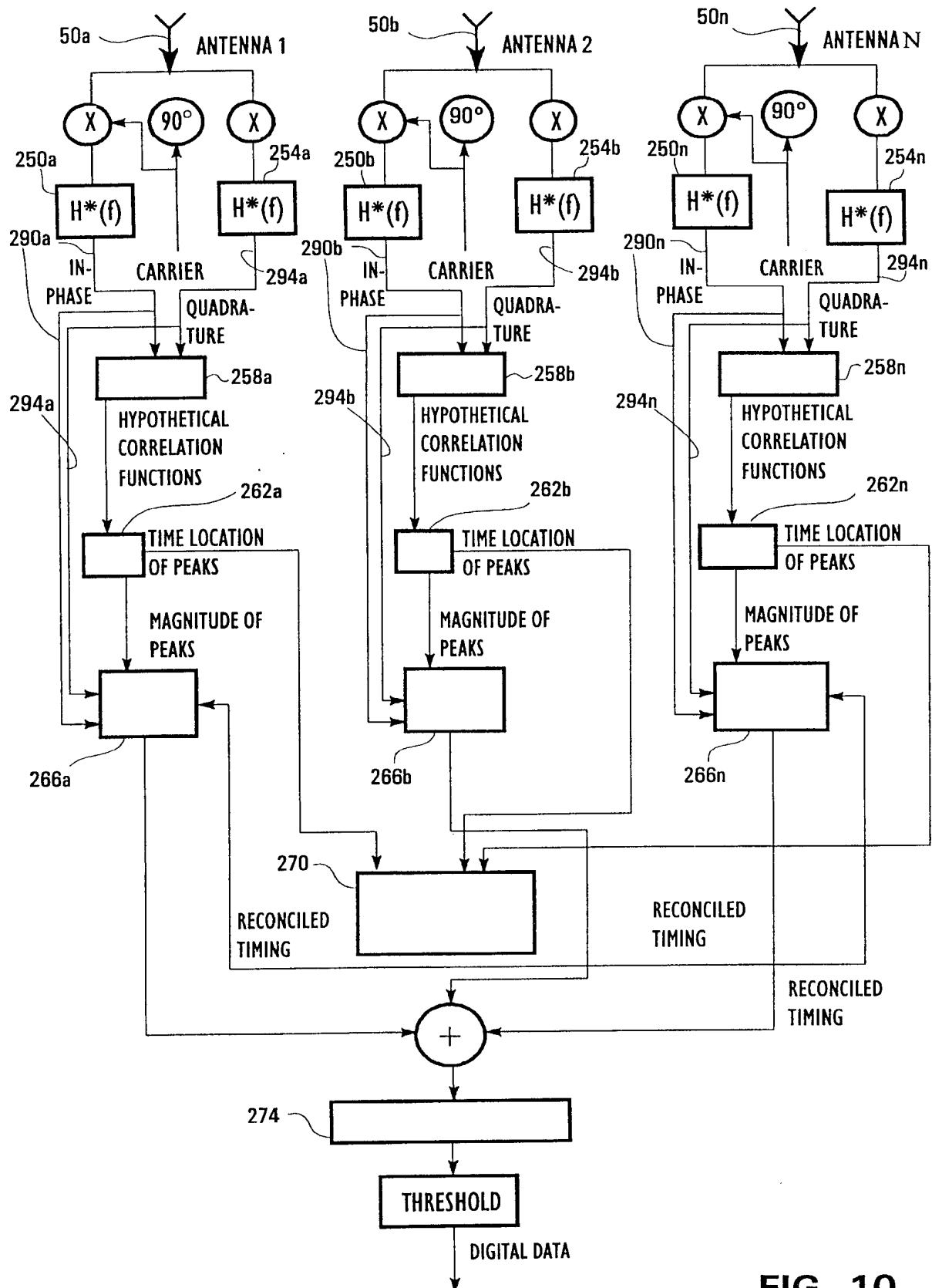

FIG. 10

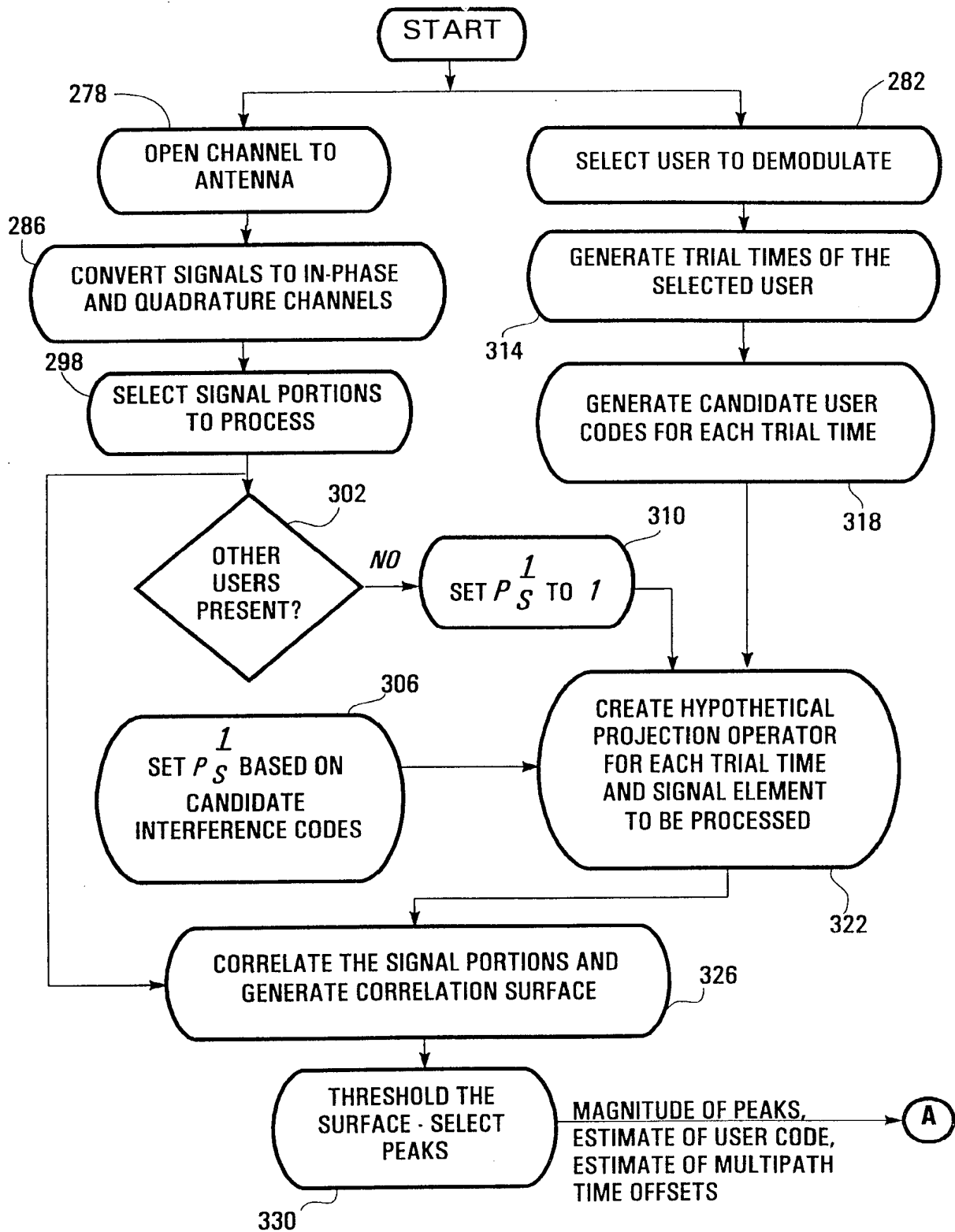

FIG. 11

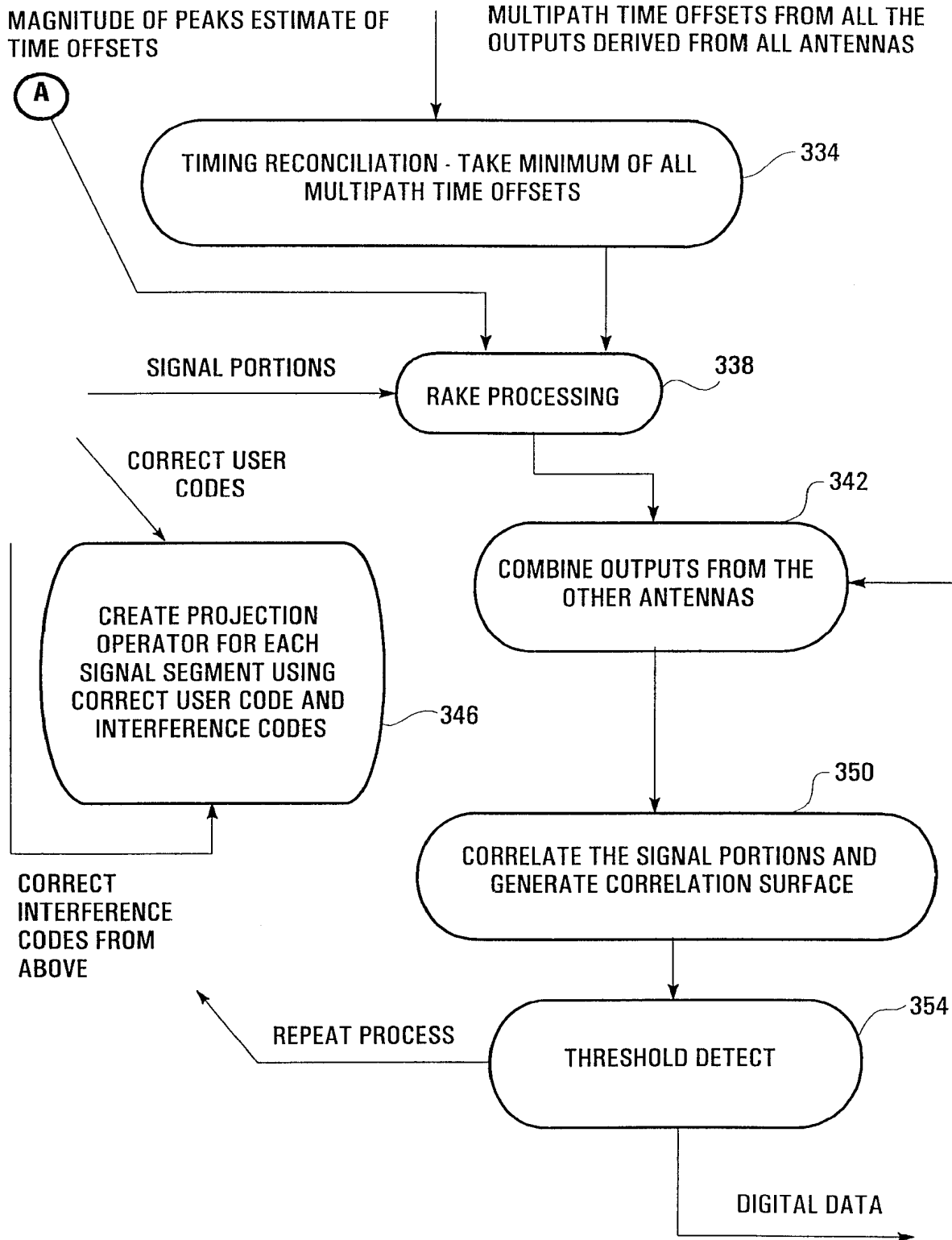

FIG. 12
SUBSTITUTE SHEET (RULE 26)

INTERNATIONAL SEARCH REPORT

International application No.
PCT/US97/14783

A. CLASSIFICATION OF SUBJECT MATTER IPC(6) :H04B 15/00, 1/10, 7/10; H03D 1/00, 1/04 US CL :375/200, 254, 340, 342, 346, 349 According to International Patent Classification (IPC) or to both national classification and IPC		
B. FIELDS SEARCHED Minimum documentation searched (classification system followed by classification symbols) U.S. : 375/200, 205-210, 254, 340, 342-343, 346-347; 370/319-321; 455/65,500,506 Documentation searched other than minimum documentation to the extent that such documents are included in the fields searched Electronic data base consulted during the international search (name of data base and, where practicable, search terms used) Please See Extra Sheet.		
C. DOCUMENTS CONSIDERED TO BE RELEVANT		
Category*	Citation of document, with indication, where appropriate, of the relevant passages	Relevant to claim No.
A	US 5,151,919 A (DENT) 29 September 1992, see abstract, and lines 39-68, and 1-13, or columns 11-12 respectively.	1-27
A	US 5,237,586 A (BOTTOMLEY) 17 August 1993, see entire document, especially col. 8, lines 56-68, and col. 9, lines 13-68.	1-27
A,P	US 5,602,833 A (ZEHAVI) 11 February 1997, see entire document, especially col. 2, lines 17-65, and col. 8, lines 34-39.	1-27
<input type="checkbox"/> Further documents are listed in the continuation of Box C. <input type="checkbox"/> See patent family annex.		
* Special categories of cited documents: *A* document defining the general state of the art which is not considered to be of particular relevance *B* earlier document published on or after the international filing date *L* document which may throw doubts on priority claim(s) or which is cited to establish the publication date of another citation or other special reason (as specified) *O* document referring to an oral disclosure, use, exhibition or other means *P* document published prior to the international filing date but later than the priority date claimed	*T* later document published after the international filing date or priority date and not in conflict with the application but cited to understand the principle or theory underlying the invention *X* document of particular relevance; the claimed invention cannot be considered novel or cannot be considered to involve an inventive step when the document is taken alone *Y* document of particular relevance; the claimed invention cannot be considered to involve an inventive step when the document is combined with one or more other such documents, such combination being obvious to a person skilled in the art *Z* document member of the same patent family	
Date of the actual completion of the international search 21 OCTOBER 1997	Date of mailing of the international search report 28 NOV 1997	
Name and mailing address of the ISA/US Commissioner of Patents and Trademarks Box PCT Washington, D.C. 20231 Facsimile No. (703) 305-3230	Authorized officer JOSEPH ROUNDTREE <i>Jan Hill</i> Telephone No. (703) 306-3033	

INTERNATIONAL SEARCH REPORT

International application No.
PCT/US97/14783

B. FIELDS SEARCHED

Electronic data bases consulted (Name of data base and where practicable terms used):

APS/STN

search terms: spread spectrum, projection, multipath, diversity receiver, correlation, RAKE receiver, RAKE processor, CDMA, oblique, non-orthogonal, time of arrival, antennae, SNR